

**SURAT PERNYATAAN PENGECEKAN
SIMILARITY ATAU ORIGINALITY**

Yang bertanda tangan di bawah ini Rektor Universitas Nahdlatul Ulama Surabaya, Menyatakan dengan sebenarnya bahwa karya ilmiah yang diajukan sebagai bahan Penilaian Penetapan Angka Kredit dan Kenaikan Jabatan Akademik/Fungsional dosen ke Asisten Ahli atas nama:

Nama : Nurul Jannatul Firdausi, S.KM., M.PH
NPP : 1305879
NIDN : 0701077002
Tempat, tanggal lahir : Pamekasan, 01 Juli 1990
Jurusan/Program Studi : S1 Ilmu Kesehatan Masyarakat
Unit Kerja : Fakultas Kesehatan
Universitas Nahdlatul Ulama Surabaya

Telah dilakukan pengecekan *Similarity* atau *Originality* karya ilmiah melalui Turnitin dengan hasil sebagai berikut:

No	Judul	Hasil
1	Identifying Waste using Value Stream Mapping to Accelerating Patient Flow: A Case Study in Emergency Department of RSUD Dr. Moewardi	0% Similarity Index
2	Trend Kasus Baru Infeksi Human Immunodeficiency Virus (HIV) di Indonesia Periode Tahun 2012-2016	24% Similarity Index

Demikian surat pernyataan ini saya buat untuk dipergunakan sebagaimana mestinya.

Surabaya, 23 April 2018
Rektor UNUSA



A. Jazidie
Prof. Dr. Ir. Achmad Jazidie, M. Eng

SHIC

by Jannatul Nurul

Submission date: 19-Apr-2018 02:40PM (UTC+0700)

Submission ID: 949610158

File name: PROCEEDING_SIHC_2017_FULL_TEXT-november_2017-395-405.pdf (626.88K)

Word count: 3037

Character count: 17306

**IDENTIFYING WASTE USING VALUE STREAM MAPPING TO ACCELERATING
PATIENT FLOW: A CASE STUDI IN EMERGENCY
DEPARTMENT OF RSUD Dr MOEWARDI**

¹ Nurul, Jannatul Firdausi; ²Trisasi, Lestari; ³Kuncoro, Harto Widodo
Public Health Program, Faculty of Health, Nahdhatul Ulama University, Surabaya.
^{2,3}(Gadjah Mada University)
Email: nuruljfunusa.ac.id

Abstract

Background: Overcrowding is a serious problem in many hospital. This condition have become global and public health problems. Spending long time to wait in ED causes queuing of patient and delaying proces of services. Emergency Department (ED one of foremost services in hospital that often faces the queuing problems. Abnormal queuing of patient causes work process very busy, appearing many problems and making medical and non medical staffs not comfortable to work. Inefficient of queuing will have impact for hospital services widely, such as quality, safety of services and hospital financial. The leader must be aware and do mitigation to increase queuing efficiency in hospital. The study aimed to understanding waste during patient treatment in emergency department until admission to inpatient unit.

Method: The study was exploratoris case study, single cases embedded design. This research conducted by non participatory observation. Study was conducted in Emergency Department RSUD Dr Moewardi and involved 45 internal patient in ED. Dala collected were quantitative and qualitative data. Quantitative was conducted by observation waiting time patient in ED who waited availability of inpatient bed and. Quantitative data interpreted by value stream mapping. Qualitative was conducted by indepth interview about influencing factors of ED-Inpatient process tha contributed delaying patient transfer.

Result: The main findings of this study (1). Waiting time patient in Emergency Department exceed of standard (< 3 hours). Total treatment time from patient arrival until delivered to inpatient room 3 hours 6 minutes 33. (2) The most occurred waste during patient treatment in emergency department until delivering to inpatient unit were waste of waiting. (3) Wasting time in ED caused multiple factors such as limited resources (human and tools), lack of coordination and communication between staff or department, hospital management system did not used optimally, problem of tool's layout and worked in fragmented department (no cross functional team work) (4) Implementation clinical cell and pull on process will increase value added of patient flow 50,4%.

Conclusion: Limited resources and lack of relation inter provider or department as main bottleneck of increasing waiting time in ED.

Keywords: Waste, Value Stream Mapping, Patient Flow

INTRODUCTION

Waiting time still be problems in most of institution, not except in healthcare. Overcrowding in Emergency Department (ED) triggers patients spend more time. This condition have become global and public health problems. Spending long time to wait in ED causes queuing of patient and delaying proces of services. Emergency Department (ED one of foremost services in hospital that often faces the queuing problems. Abnormal queuing of patient causes work process very busy, appearing many problems and making medical and non medical staffs not comfortable to work. Inefficient of queuing will have impact for hospital services widely, such as quality, safety of services and hospital financial. The leader must be aware and do mitigation to increase queuing efficiency in hospital. (Rundolph, 2010).

Inpatient boarders increases burden in ED. Indpatient boarders in ED are significant contributor among patient queuing in ED. Research finding of White *et al.*, (2013) shown that inpatient boarders caused lenght of stay in ED increased 57 minutes and related to limited capacity. Another research by Litvak, *et.al* (2002) find interasting fact that inpatient boarder in ED caused beds can be limited for new patient. Emergency Department in RSUD Dr Moewardi has same problem related to

waiting time of inpatient boarders. Observation of 14 patient in internal inpatient room shown 57, 14% patient spend long time in ED for waiting 3rd class inpatient beds available. Waiting time problems can be fixed with adopted *Lean*. *Lean* is a way to increase services quality to patient by reducing errors and waiting time. The fact of implementation *lean management* in Thedacare Wiconsin. This healthcare can reduce waiting time of orthopedy from 14 weeks to 31 hours (Grabam, 2012).

METHOD

The study was exploratoris case study, single cases embedded design. Case study was choosen to investigate waiting time patient in ED who waited availability of inpatient beds, and influencing factors of ED-Inpatient process. Research conducted by non participatory observation. Research finding during observation become basic data to collected qualitative data. Result interpretation used data from qualitative and quantitative finding. Collection data was conducted in Emergency Department and Inpatient RSUD Dr Moewardi. The hospital such teaching hospital type A, IGD tipe IV with number of inpatient beds amount 808 beds. ED visitors during 2012 until 2014 amount 58.525 by year and 30% from ED visitor were internal patient.

Study was conducted during April until July at 2015. Respondent for real time observation has chosen amount 45 patient. Inclusion criteria such as respondent with internal cases, patient decided to inpatient in RSUD Dr Moewardi, Patient severity did not increased during treatment in ED. Exclusion criteria such as, patient decide to outpatient, patient referred to another hospital, patient severity increased until entered to ICU, resuscitation or death. Researcher conducted examination of observation sheets before. Data processing, analysing of result, also repairing of interview guidelines. Observation data interpreted by descriptive such as mean and drawing wait time in *Value Stream Mapping*. Qualitative data translated by transcript and code by matrix.

RESULT

Waiting Time of Referral and Walk-In Patient

Patient arrived in ED, included as referral and walk-in. General waiting time, started to patient arrived until patient left from ED during 3 hours 6 minutes 33 second. Patients admitted to transitional admissions were considered to have entered to inpatient room, while patient got treatment in transition room until 3 days. The main difference of transition room than another inpatient room were lack of facility

and health workers ability especially for patient who need intensive care.

Most of services duration between referral not different with walk-in patient. Referral patient spent long time in registration to entered ED, preparation for inpatient registration, patient registration. Table below shown overview of waiting time for referral and walk-in patient during in ED until entered to inpatient:

Table 1. Waiting Time of Patient Referral and Walk-in in Emergency Department RSUD Dr Moewardi

No	Services process in IGD-Inpatient	Waiting Time	
		Referral patient (minute)	Walk-in patient (minute)
1	Patient arrival	2 minutes 30 second s/d 5 minutes 15 second	2 minutes 38 second s/d 5 minutes 28 second
2	ED Registration	11 minutes 10 second s/d 26 minutes 49 second	7 minutes 50 second s/d 21 minutes 8 second
3	Patient Observation	1 hours 38 minutes 35 second s/d 4 hours 11 minutes 43 second	1 hours 41 minutes 29 second s/d 4 Hours 52 minutes 51 second
4	Preparation of Inpatient Registration	24 minutes 15 second s/d 57 minutes 42 second	12 minutes 19 second s/d 43 minutes 51 second
6	Cheking of drug use and verification	2 minutes 58 s/d 17 minutes 42 second	4 minutes 20 second s/d 26 minutes 32 second
7	X-Ray Treatment	8 minutes 0 second s/d 32 minutes 28 second	5 minutes 6 second s/d 24 minutes 23 second
9	Entering to Inpatient Room	9 minutes 23 second s/d 13 minutes 21 second	8 minutes 24 second s/d 12 minutes 4 second

Sumber: Data Primer

Waste during Treatment in ED until Inpatient Room

During treatment in ED, observation was the longest process with the largest Non Value Added (NVA) activity and complex waste dominance. Overall, waste during IGD-Inpatient treatment included *Waste of Waiting, Motion, Transportation, Overprocessing, Overproducing, Defect dan Humant Talent*. Implementation clinical cell and pull improved patient flow (VAR) 50,34 %.

Table 2 *Waste* During Services in ED-Inpatient RSUD Dr Moewardi

No	Services process in IGD-Inpatient	Time Average (second)	Activity (second)			Waste
			VA	NVA	NNVA	
1	Patient arrival	303.30	136.88	120.02	46.40	<i>Waste of Waiting, Motion, Human Talent</i>
2	ED Registration	1151.98	618.40	441.22	92.36	<i>Waste Waiting, Motion, Defect, Overprocessing</i>
3	Patient Observation	22326.29	8278.22	13906.50	141.57	<i>Waste of Waiting, Motion, Overprocessing, Defect, Human Talent, Transportation, Overproducing,</i>
4	Preparation of Inpatient Registration	1255.04		926.78	327.78	<i>Waste of Waiting, Motion, Overprocessing</i>
5	Inpatient Registration	535.54		254.44	281.10	<i>Waste of Waiting, Motion, Overprocessing, Transportation</i>
6	Cheking Medical Record in Pharmacy	211.42		74.84	136.58	<i>Waste of Waiting, Motion, Transportation</i>
7	Verifying Medical Record	412.11		249.00	163.11	<i>Waste of Waiting</i>
8	X-Ray Treatment	1316.84	728.34	495.91	92.59	<i>Waste of Waiting, Motion</i>
9	Entering to Inpatient Room	634.75	395.09	196.33	43.33	<i>Waste of Waiting</i>

Keterangan: NVA= Non Value Added; VA= Value Added; NNVA = Necessary but Non Value Added

Value Stream Mapping During Services in ED-Inpatient

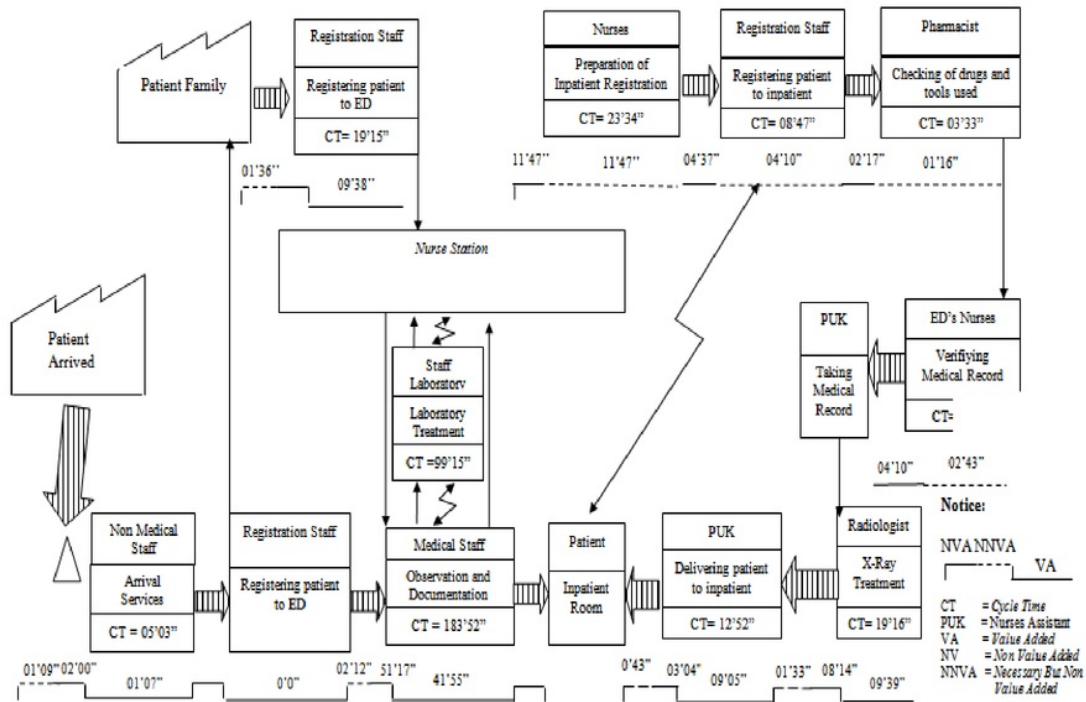

Gambar 1 Value Stream Mapping During Services in ED-Inpatient RSUD Dr Moewardi

6

Future State Map Penerapan Clinical Cell dan Pull

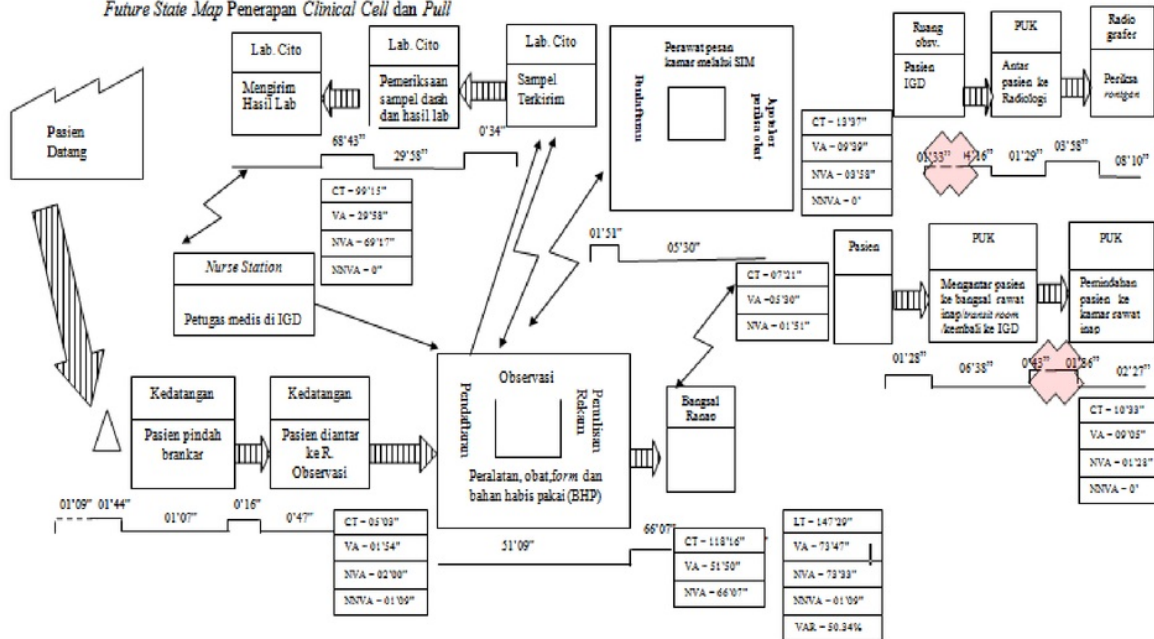

Gambar 3 Future State Map Penerapan Clinical Cell dan Pull pada Pelayanan IGD-Rawat Inap RSUD Dr Moewardi

DISCUSSION

1. *Waste of Waiting*

The most occurred wasted during patient treatment in ED was waiting. Waste of waiting has occurred since patient arrival. Patient waited to moved on bed/brankar to delivering on medical room. No health workers in ED front office due to moving activity must be handled by non-medical staff and Triage was not optimal. The main difficulty of condition to decided walk-in patient was emergency and not referred as outpatient if polyclinic still open. Non-medical staff should communicate with medical personnel within ED and automatically this activity added waiting time.

Increasing patient visits lead to overcrowding in ED. This condition was exacerbated by unbalanced resources especially related to human resources, medical devices and even non-medical support facilities. Facing this condition, officers at the forefront of ED should educate patient's family to explained the real condition of ED that ED was busy or even unable to accepted new patients due to resource constraints. Education was a way to equated perception of officers and family to avoid patient's rejection opinion, but the activity also added patient waiting time to got medical services.

Waiting frequently occurred during 07.00-13.59. Response time at period almost reached time standard time. The condition indicated still long time spending by patient to got first service by medical staff at ED. Mutually waiting for the appliance, waiting for officer to put on personal protection equipment (PPE), waiting for a specialist to provided services and waited for the laboratory result sent to ED were activity that aggravated waiting time of patient during observation. Triage process and fast track service has not been implemented optimally in ED of RSUD Dr Moewardi, although SOP related to the service has been arranged in Director's Regulation number 1884.4 / 316A/2013 about Dr Moewardi Hospital service. Space limitations was a main reason the process can not be done. Fast track service was intended to provided fast and precised service and shorten waiting time of patients with green code during getting treatment in ED. Not optimal fast track implementation due to green patients (less serious seriousness) accumulation and the waiting time to be longer because the medical officer put medical service for emergency patient.

Waiting for laboratory results was the longest part of observation, which reached more than 1 hour. The standard of laboratory examination based on

Health Ministry Regulation No. 129 in 2008 about Minimum Service Standard of Hospital mentioned duration of laboratory examination ≤ 140 minutes (2 hours 20 minutes), while time standard of laboratory examination in RSUD Dr Moewardi was 2 hours. But laboratory ED as cito laboratory so test result should come out faster. Duration of Delivering laboratory test result often complained by the medical staff because inhibited the diagnosis. Patients who were admitted to inpatient room must also waited long enough to be sent to the inpatient.

Activities done in a separate room were very susceptible to misinformation so both patients and officers experienced a waste of time to wait. During activities carried out between units, potential for fragmented information and data duplication was enormous. Weak integration of information systems exacerbates this condition (Khodambashi, 2014). Waste of time due to waiting for delivery between units can also occurred due to poor document and material arrangement so that 5S implementation can be a way to solved the problem. (Buesa, 2009). Related to delayed transfer of patients to inpatient room, Powell *et al.*, (2012) has conducted research in di teaching hospital of *Massachusetts, Boston*

finding relationship between patient discharge and accumulation patient transition in ED. Shifting of patient discharge 1 hour earlier from peak time at 2 pm and 3 pm may decrease patient stay at ED by 50%. Patient discharge 4 hours earlier between 8 am and 4 pm can overcome 75% of transition patient queue at ED. Hall *et al.*, (2006) also have same opinion regarding accuracy of inpatient discharge and delayed in preparing rooms also affected the smooth transfer of patients.

2. *Waste of Motion*

Waste of motion was a wasting time due to officers and patients movement were excessived waiting time. Motion occurred as a result of improper layout of patients, tools and documents. Motion also occurred due to lack of resources numbers. Waste during patient service at the emergency room may occurred from arrival to observation. Waste potentially occurred at arrival, mainly during peak time and number of medical support facilities, such as bed, stretcher and other medical devices were not available. Conditions caused officers needed to seeking it to accepted new patients coming.

During observation waste of motion often occurred when loss of triage form (checklist), medical support tool, medical record or even wrong taking material and run out of material while doing observation. This condition occurred due to during observations conducted by different medical personnel. Task distribution for ED medical personnel has been done when morning pre-conference, but during process, implementation of task distribution has not been applied optimally. Staff awareness and compliance to placing medical support equipment in the right place, such as GDS, stethoscope, tensimeter was not optimal. Lack of medical facilities also contributed to occurrence waste of motion. Improper communication between staff and inter-departments caused waste of motion, such as misdirected patients, obscurity in the introductory examination sheet.

3. *Waste of Transportation*

Service at ED was interconnected with many work units, but not supported by an integrated information system so staff had to transfer files between units, such as pharmacists delivered to nurse station after completed checking medical record. Waste also occurred when doctors had to write medical

records. Frequently, doctors should perform writing medical record and checking patient at adjacent time intervals and needed to walk between nurse-doctor station to observation room of patient.

Medicines and medical aids for patients were taken in Outpatient Pharmacy, although distance of pharmacy and observation room were not too far away, but repetition of requests encouraged staff back and forth to pharmacy. The waste continued until staff had to take trolley to put drugs and tools from pharmacy to started treatment, such as infusion. Work in ED required to provide fast and precise services so waste due to layout will extend patient waiting time need to be improved. Referring to Health Ministry RI on Building Guideline of ED Room, medicines and medical supporting equipments can be stored cabinet, for special requirement in ED (Kementrian Kesehatan RI, 2012).

4. *Waste of Overprocessing*

Waste often occurred during patient observation and registration. Lack of human resources and inadequate task distribution contributed to waste occurrence. During observation nurses and doctors have done double handling in dealing with patient so delaying work

who handled by them, for example nurse postponed to check patient's admission to hospital file for seeking other patient oxygen. Nurse needed time about more than 6 minutes to finished it. Conditions not only added observation waiting time but also improved waiting time of transition patient. The waste potentially occurred during patient registration, either arrived in ED or admitted on inpatient. No clear task distribution between personnel. Registration staff attempted to minimizing queue of patient-family so frequently handled more than 2 patients registration, especially when filling general consent so completion general consent by patient was under control average time to filled general consent more than 4 minutes.

5. *Waste of Defect*

RSUD Dr. Moewardi was teaching hospital. Many student learned in ED, such as co-ass and nurses student. Students practiced had to be supervised by senior medical staff but overload on handled task made supervision activity not optimal. So students treated patient alone and often practiced repetition actions, such as blood collection, investigation or installation of aids.

6. *Waste of Inventory*

Waste of inventory was not only related to excessed stock of drugs, consumables materials and equipment. Waste of inventory also associated with accumulation, both patients and documents due to queue and waited to be served. Waste often occurred in ED administration unit, such as queue of patient's family usually occurred when improvement patient visits and impact on accumulation of medical records file for patients registered to inpatient room. Waste of inventory also occurred while checking drug usage history in medical record at pharmacy. Waste also occurred in observation especially waiting for an internist specialist, inventory of laboratory examination result. Accumulation on patient and medical record files waited to be consulted with the doctor.

7. *Waste of Human Talent*

Waste of human talent related to staff ability in providing services. Waste of human talent frequently occurred when treatment was done by student, for example repetition in investigation because of misplaced equipment, not understood to operate pneumatic tube for sending body liquid (blood). There was no provision for stages of students practiced ED. Mentoring factors from

senior staff also triggered human talent. Human talent also occurred when accepted patient arrival usually related to responsiveness of non-medical personnel to make transfer and delivery of patients appropriately.

CONCLUSION

Waiting time patient in Emergency Department exceed of standard (< 3 hours). Total treatment time from patient arrival until delivered to inpatient room 3 hours 6 minutes 33. The most occurred waste was waste of waiting. Implementation clinical cell and pull will increase value added of patient flow 50,4%. Limited resources and lack of relation inter provider or department as main bottleneck of increasing waiting time in ED.

RECOMMENDATION

Suggestion for improvement patient flow in ED-Inpatient by maximizing existing resources, such as optimization triage and fast track service, facility improvements such as information boards, guidance sign and facilitation of patient delivery officers with communication tools, organizing hospitalized patient discharges.

REFERENCES

Buesa, R. J. (2009). Adapting lean to histology laboratories. *Annals of Diagnostic Pathology*, 13(2009), 322-333.
<http://doi.org/10.1016/j.anndiagpath.2009.06.005>

- Graban, M. (2012). *Lean Hospitals: Improving Quality, Patient Safety and Employee Engagement* (Second). New York: CRC Press.
- Hall, R., Belson, D., Murali, P., & Dessouky, M. (2006). Modeling Patient Flow Through The Healthcare System. In R. W. Hall (Ed.), *Patient Flow: Reducing Delay in Healthcare Delivery* (pp. 1-44). Los Angeles: Springer Science&Business Media.
- Kementrian Kesehatan RI (2012). Pedoman Teknis Bangunan Rumah Sakit Ruang Gawat Garurat.
- Khodambashi, S. (2014). Lean Analysis of an Intra-operating Management Process - Identifying Opportunities for Improvement in Health Information Systems. *Elsevier*, 37(1877), 309-316.
<http://doi.org/10.1016/j.procs.2014.08.046>
- Powell, E. S., Khare, R. K., Venkatesh, A. K., & Roo, B. D. Van. (2012). The Relationship Between Inpatient Discharge Timing and Emergency Department Boarding. *Journal of Emergency Medicine*, 42(2), 186-196.
<http://doi.org/10.1016/j.jemermed.2010.06.028>
- Rundolph, M. E. (2010). The Problem of Patient Flow. In E. Litvak (Ed.), *Managing Patient Flow in Hospitals: Strategies and Solutions* (Second Edi, pp. 3-14). Illinois: Joint Commission on Accreditation on Healthcare Organizations.
- White, B. A., Biddinger, P. D., Chang, Y., Grabowski, B., Carignan, S., & Brown, D. F. M. (2013). Boarding Inpatients In The Emergency Department Increases. *Journal of Emergency Medicine*, 44(1), 230-235.
<http://doi.org/10.1016/j.jemermed.2012.05.007>

SHIC

ORIGINALITY REPORT

0%

SIMILARITY INDEX

0%

INTERNET SOURCES

0%

PUBLICATIONS

0%

STUDENT PAPERS

PRIMARY SOURCES

Exclude quotes On

Exclude bibliography On

Exclude matches < 1%